

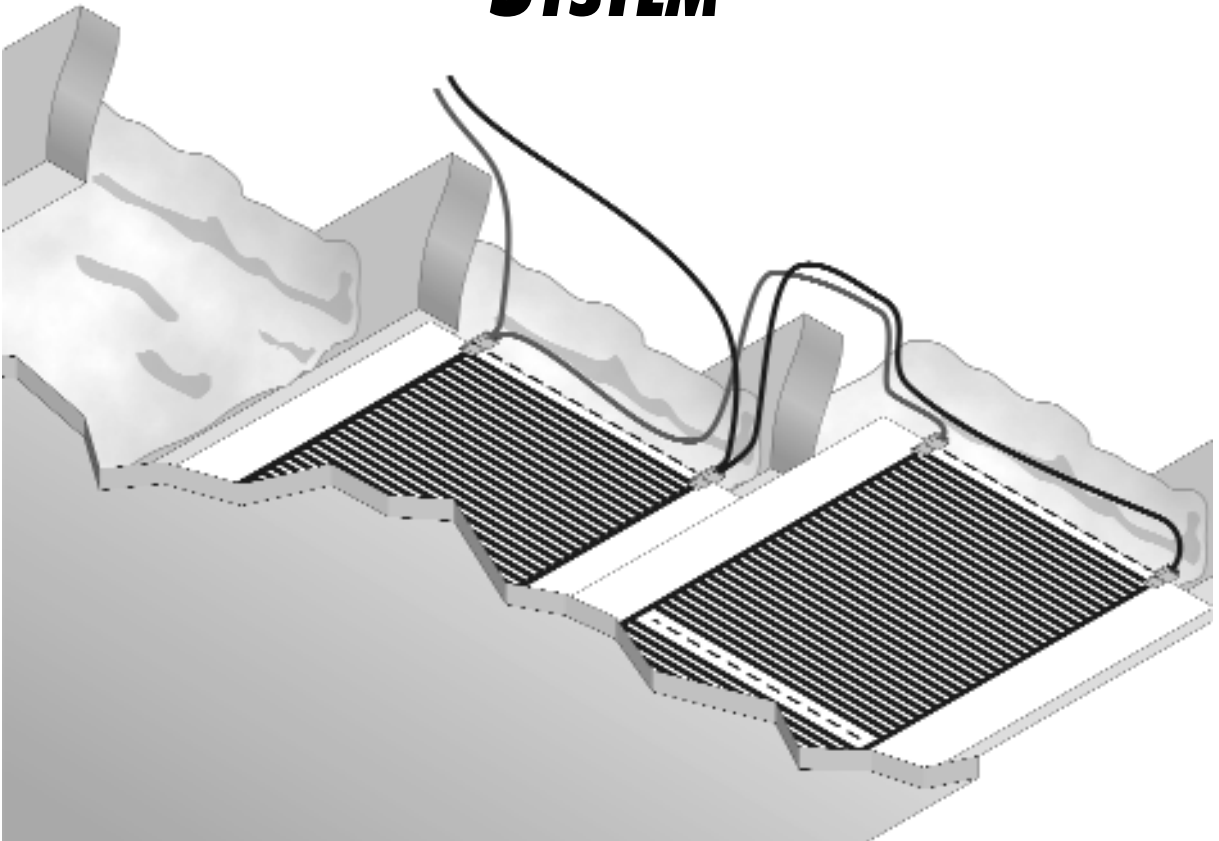

RADIANT CEILING HEATING SYSTEM



Installation Manual



INTRODUCTION



THE INSTALLATION OF THIS HEATING PRODUCT SHALL BE IN ACCORDANCE WITH THE MANUFACTURER'S INSTRUCTIONS AND THE REGULATIONS OF THE AUTHORITY HAVING JURISDICTION.



The installation of this heating product shall be in accordance with Article 424, Part J, of the National Electrical Code, ANSI/NFPA 70.



THIS EQUIPMENT SHALL BE INSTALLED ONLY BY QUALIFIED PERSONNEL WHO ARE FAMILIAR WITH THE CONSTRUCTION AND OPERATION OF THE APPARATUS AND THE RISKS INVOLVED.



Heating elements should not be installed at or below 32°F (0°C).

The Calorique Radiant Ceiling Heating System (RCH) is a unique heating system that is installed on the underside of the ceiling joists to provide either primary or supplementary heat. The RCH System consists of low heat density panels that cover the majority of the ceiling surface to ensure optimum thermal comfort.

Installation is straight-forward: start by calculating the heating load and designing the system, then cut the heating panel sets to length, staple them into position on the ceiling joists and electrically connect them together.

There are four sections of this manual:

Part 1 - Design Criteria is to be used by the heating system designer. This portion of the manual will generally be followed in the design office. The designs and drawings completed during this stage must be made available to the installer(s).

Parts 2 - Job-Site Preparation, 3 - Installation and 4 - Inspection • Testing • Completion will be used by the actual heating system installers. *Job-Site Preparation* provides a complete list of the materials and supplies that must be on hand during the installation and testing of the system. *Installation* and *Inspection • Testing • Completion* detail the actual installation and testing of the system.

Throughout this manual four types of notes will direct your attention to important information that must be taken into account during the planning and installation of the Calorique RCH System.



This symbol indicates that a fire hazard may exist if a particular action is not followed.



This symbol indicates that a shock hazard may exist if a particular action is not followed.



General notes direct you to pay special attention to these items.

NOTE

Notes provide short tips for making the installation easier or convey information that falls outside of the direct text of the manual.

The Calorique Radiant Ceiling Heating System is made up of 4 major components: the heating panels, the wiring, the control device and the ceiling structure. These components work together to create a system that will provide comfortable, trouble-free heating. The selection and installation of each component is very important to the system's overall safe operation.

Designing a Calorique Radiant Ceiling Heating System is straightforward — the following instructions must be followed to ensure a trouble-free design and to comply with the warranty requirements.

NOTE

A Planning Guide is available to assist in the determining the type and quantity of components that are required.

HEAT LOSS CALCULATION

A heat loss calculation *must* be completed to determine the energy required to adequately heat the space under foreseeable circumstances. The Air Conditioning Contractors of America (ACCA) Manual J includes worksheets for manually calculating the heat loss of a structure. Other, comparable, heat loss methods and/or documents may be used. Make sure that all sources of heat loss (transmission, infiltration and radiant) are taken into account.

As bathrooms typically have small ceiling surface areas with recessed fixtures in them, the maximum possible amount of installed heat is often insufficient to supply the demand. Bathrooms and other areas where there is not enough available ceiling space to allow installation of sufficient Calorique heating panels to act as a sole source of primary heat must use a supplementary or alternative heat source, such as high power radiant panels, baseboard heaters, etc.

NOTE

Some heat loss methods, particularly those designed for gas and oil based systems, provide their answers in BTUS PER HOUR. To convert BTUS PER HOUR to WATTS, multiply each area total by 0.293.

NOTE

Always include a recovery factor of at least 20% more than the minimum calculated heat requirement to cover unforeseen circumstances.

CONTROL DEVICE OPTIONS

The fuse or circuit breaker used must be rated for a maximum of 20 amperes (no greater than 16 amp load). If a lower rated fuse or circuit breaker is used, it must be rated at least 25% greater than the heating system load attached to it. If an area requires more than the 16 amperes allowed, additional branch circuits may be used, each having its own overcurrent protection. These branch circuits may all be controlled by a single thermostat if it is used with a system of electric relays.

NOTE

ACCA may be contacted at 202-483-9370, 1712 New Hampshire Ave. NW, Washington DC 20009.



A separate heat loss calculation must be done for each enclosed area (room, etc.). A separate control device must be included for each enclosed area.



Do not install Calorique in any bathroom, room or other enclosure which does not have at least as much heat installed as is called for by the heat loss calculation, plus the recovery factor.



All wiring, fuses and/or circuit breakers must conform to National Electrical Code requirements.

The Calorique Radiant Ceiling Heating System can be controlled by any standard line voltage method — including line voltage thermostats or low voltage thermostats in conjunction with line voltage relays. Whichever control option is used, all components must meet all applicable local and national codes and be rated for use with an electrical heating system.

NOTE

The National Electrical Code specifies that each branch circuit used in conjunction with a heating system must be for the exclusive use of the heating system. Do not connect lights, outlets, etc. to any branch circuit used with the Calorique Radiant Ceiling Heating System.

CEILING CONSTRUCTION



Metal joists, furring strips and/or resilient channel must be properly grounded in accordance with local codes.



The ceiling surface must be installed so that it maintains good contact with the Calorique heating panels.



All heating panel sets within one room shall be covered by the same facing material, having the same thermal resistance.



Do not use suspended ceilings, plastic ceiling tiles or lathe-and-plaster in conjunction with the Calorique system.

Joists — The Calorique Radiant Ceiling Heating System is designed for use with typical wood and/or metal ceiling joists and/or furring strips and/or resilient channel. The joists or furring strips must have a facing width no greater than 2 inches (50 mm). The spacing between the joists or furring strips must be 12, 16 or 24 inches on center (300, 400 or 600 mm). If joists are spaced at non-standard distances, furring strips must be installed using one of these spacings.

Ceiling Surface — The ceiling surface may be of any material having a thermal insulation value of less than R-0.6 (RSI-0.105) — this includes any skim coat, texture and/or vapor barrier, as well as secondary materials added to the ceiling at a later time. The following table gives typical values for common building materials used for ceiling surfaces. Contact the material manufacturer for specific information concerning the thermal insulation factor of the material being specified.

Material	Typical R-Factor
Up to $\frac{5}{8}$ inch (16 mm) gypsum board	R-0.56 (RSI-0.098)
Up to $\frac{1}{4}$ inch (6 mm) plywood	R-0.31 (RSI-0.054)
Up to $\frac{3}{8}$ inch (9 mm) solid wood panel	R-0.51 (RSI-0.089)

Surface Finish — Any type of surface finish can be applied to the finished ceiling. The total thermal insulation value of the ceiling covering and finish must not exceed R-0.6.

NOTE

Note that skim coats can not be applied to the maximum thickness of plaster (gypsum) board. When a skim coat is to be used, the plaster board must be less than $\frac{5}{8}$ inch thick by the thickness of the skim coat — i.e. a $\frac{1}{8}$ inch thick skim coat may be applied to gypsum board no greater than $\frac{1}{2}$ inch thick.

NOTE

Use reinforced tape to join gypsum boards to help avoid hairline cracks in the joint compound.

NOTE

Some oil based paints may discolor when subjected to the direct warmth of the Calorique system.

NOTE

Do not use the Calorique system to cure paint or joint compound since direct heat during curing may cause cracks or discoloration.

Insulation — The only types of insulation permitted with the Calorique system are:

- Unfaced fiberglass batt insulation
- Rigid insulation panels
- Blown-in fiberglass insulation

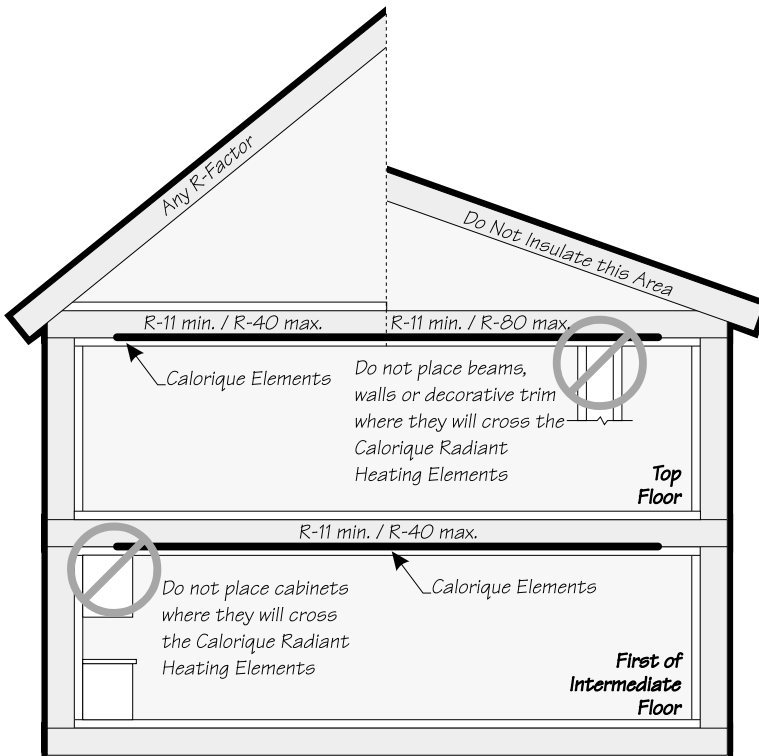
**NOTE**

All walls, ceilings and floors that separate a heated space from an unheated space or the out-of-doors must be insulated to ensure proper operation of the system.

In those areas where a vapor barrier is required, the barrier should be installed after the heating panels and wiring (this will keep the wiring from having to pierce the vapor barrier which would render it useless). If local code requires that the vapor barrier go up first, make sure that any holes created during the installation of the heating system are sealed. Polyethylene vapor barriers of up to 0.008 inches (0.20 mm) thick may be used.



Use only non-combustible insulation.



Blown-in insulation may only be used when installed in accordance with the instructions on page 15. Extreme care must be taken to ensure that no blown-in insulation becomes trapped between the heating panel and the ceiling surface. Insulation which becomes trapped is a potential fire hazard.



Do not use cellulose insulation of any kind.



Do not use insulation greater than R-40 (RSI-7) in interior ceilings or R-80 (RSI-14) in exterior ceilings. See 14 for additional information on insulation.



Do not use metal foil faced insulation or metallic vapor barriers.



Do not install this system in walls, vertical partitions or sloped ("cathedral") ceilings.



WARNING: Risk of electric shock and fire. Damage to supply conductor insulation may occur if conductors are routed less than 2 inches (51 mm) from this heating product. Refer to installation instructions (page 12) for recommended means of routing supply conductors.



Do not use metal foil faced insulation or metallic vapor barriers.

DESIGN CLEARANCES

When designing the heating system, care must be taken to ensure that proper clearance is maintained from other fixtures, furniture, etc. which may be in contact with, or part of, the ceiling.

Decorative trim — Calorique heating panels must be installed so that they will not be covered, even in part, by decorative trim or beams or other structures that cross the ceiling. Heating panels which are covered by other structures may overheat.

Track lighting — Do not install track lighting where it will cross over the heating portion of the Calorique heating panels. If track lighting is to be used, its location must be determined before design and installation of the Calorique heating panels.

Wiring — Electrical wiring, in the ceiling must be at least 2 inches (51 mm) away from the heating panels with a barrier of insulation filling that space.

Surface Mounted Fixtures — Do not install Calorique heating panels closer than 8 inches (200 mm) from the edges of any electrical boxes for surface mounted fixtures in the ceiling (or the floor above).

Recessed Fixtures — At least 2 inches (50 mm) of clearance must be maintained between the trim of recessed fixtures and the Calorique heating panels.

Heat Sources — At least 8 inches (200 mm) of clearance must be maintained between heat sources and the Calorique heating panels. This includes hot water pipes. If not possible, use pipe wrap on pipes.

End of Joist Bays — Leave at least 6 inches (150 mm) of clearance at each end of each joist bay to accommodate wiring and assembly.

HEATING PANELS

Heating Panel Set

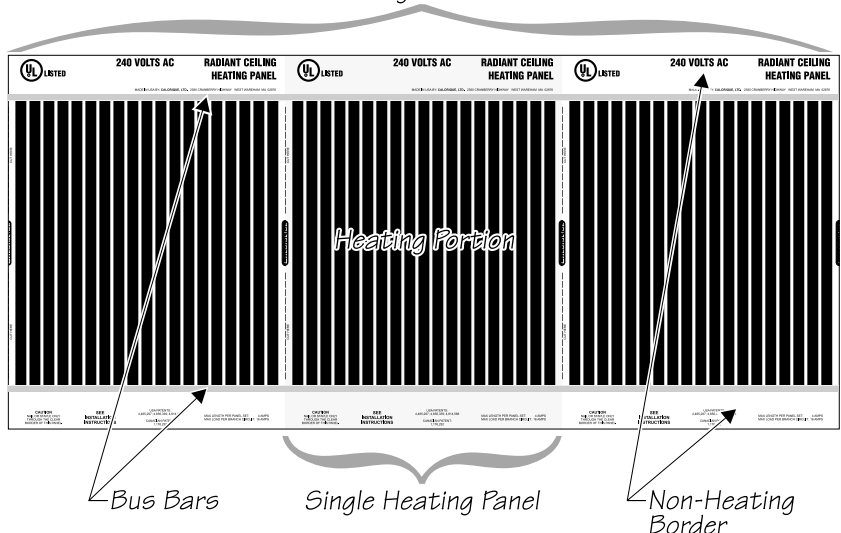

A typical Calorique heating panel set.

Calorique's Radiant Ceiling Heating System is available in three standard sizes and two standard voltages. Match the joist spacing and voltage available to the appropriate heating panel(s) in the following table:

Joist Spacing	Watts / Panel	240 Volts AC
12 inch (300 mm) max. length:	13	RCH13P13W240V 55 panels
16 inch (400 mm) max. length:	17	RCH17P17W240V 42 panels
24 inch (600 mm) max. length:	25	RCH25P25W240V 29 panels

NOTE

If a particular room or area includes more than one joist spacing (e.g. some joists spaced at 12 inches and some spaced at 16 inches), you must use the appropriate heating panel for each joist spacing. Alternatively, add strapping (furring strips) to the undersides of the joists at a single, constant spacing.

The maximum length for a particular model means the maximum continuous length of heating panels for any one run, or panel set. This length is governed by the maximum amperage that the bus bars are designed to carry.

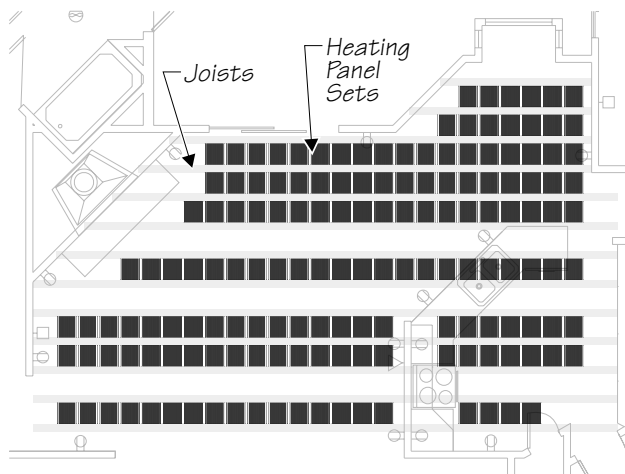

Typical Calorique Radiant Heating System layout. Locate panels mostly in those areas that will have higher heat loss (see the heat loss calculation) then distribute the rest of the panels over the remainder of the ceiling. Be sure to provide sufficient space between the panels and any external source of heat (chimneys, electrical boxes, duct work, gas or wood burning equipment, etc.).

The total number of panels used in a single circuit is limited to 16 amps. Use the following table as a quick reference when specifying only single voltage/width heating panels. When specifying multiple width heating panels for the same area, make sure that the total power (watts / panel times the number of sections for all product types) is less than or equal to the maximum total power figure.

Voltage	Maximum Total Power	Maximum Total Panel		
		12 inch	16 inch	24 inch
240	3840 watts	295	225	153



Make sure that the job-site is neat and clean before working with the Calorique radiant heating panel sets. Nails, screws and other sharp debris can damage the panels. Any panels which become torn or otherwise damaged must be discarded.

Make sure that the job-site is neat and clean before working with the Calorique radiant heating panel sets.

Nails, screws and other sharp debris can damage the panels. Any panels which become torn or otherwise damaged must be discarded.

PREPARATION

Before work can proceed, all plumbing and electrical wiring that will not be accessible after installation of the heating system must be completed. This may require coordinating with the electrical and/or plumbing contractor(s).

Make sure that insulation has been installed in areas that will be inaccessible after installation of the heating system. This may require coordinating with the insulation contractor.

When furring strips are used, install them with a center-to-center spacing equal to that required by the heating panels that are going to be installed. The area below each existing joist must be insulated to eliminate an air space.

Fill Area Between Furring Strips with Insulation

Pat Insulation Down Flush with Bottoms of Furring Strips

DO NOT Leave Air Gap Below Joists

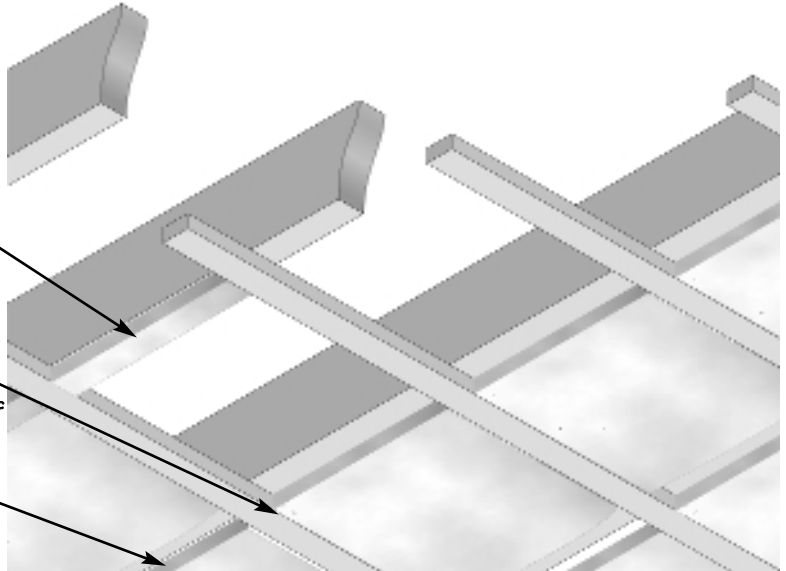

Heating panel sets which will be insulated with blown-in insulation must be accessible from above at least until the insulation is installed to allow for the installation of batt insulation "dams" — see page 15.

Before installing the Calorique Radiant Ceiling Heating System, all of the following must be available at the job-site.

COMPONENTS

NOTE

Those components marked with the • symbol are supplied by your Calorique distributor.

Name	Part Number	Description
•Heating Panels	see table 5	The number and type of heating panels needed must have been calculated before-hand as outlined in Part 1-Design Criteria. Enough panels must be on hand to account for any errors in cutting, job-site damage, etc.
•Electrical Connector	FC-1001	Solderless Tyco/AMP Termi-foil electrical crimp connector. Two required for each panel set.
•Electrical Insulator	FB-1001	Clear plastic snap-type insulator. Two required for each panel set.
Thermostat		UL listed thermostat rated for at least 25% greater capacity than the installed heating load. Low voltage units may be used in combination with appropriate relay.
Thermal Insulation		The insulation must be of the non-flammable type specified during calculations done per Part 1. See page 3 for details.
•Warning Labels	CW1006 CW1008 CW1009 CW1010	These four labels are an integral part of this heating system and must be installed for the warranty to be in force. See page 16 for details on affixing these labels. One of each type label is provided for each 16 meters of heating panels (50 panels).



If insulation is being installed by another contractor, this information must be made available and compliance ensured.

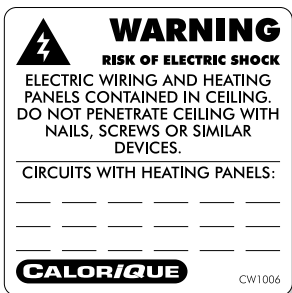



Type NM and NMC non-metallic sheathed cable is not suitable for installing this product.



Caution: Use copper only as supply conductor.

Name	Part Number	Description
Non-Heating Leads		Branch circuit supply conductors shall be no larger than #12 AWG or smaller than #14 AWG, with overcurrent protection of 20 amperes. Type UF single conductor or equivalent.
Dielectric Tape		UL listed "electrical" tape rated for at least 90°C (194°F).
Duct Tape		This tape is required when performing retrofit installations as outlined on page 10. The tape must be UL listed and rated for at least 90°C.
Ohm-Meter or Multi-Meter		An accurate ohm or multi-meter will be used during the testing phase to ensure that the system is correctly installed. It is suggested that a digital meter is used rather than an analog (needle) type.
• Instruction Manual	CM1001	This document.
• Check List & Information Card	CL2001	The installation check list and information card must be sent to Calorique, which in turn will send a warranty registration card.
• Operating Manual	CM1002	The operating manual lists detailed information about the heating system. This manual must remain in the building when the job is done.

TOOLS

Name	Part Number	Description
• Combination Crimping Tool	FCT-104	Used to attach electrical connectors to the heating panels and wires to the connectors. Manufactured by Harbin Sanzing Calorique Heating Company, Ltd.
Staple Gun		Standard automatic stapler. Used to attach Calorique panels to ceiling joists. Recommended staple length: 5/16 or 3/8 inch (8 or 9.5 mm).
Assorted Hand Tools		Conventional electrical wiring hand tools.
Knife and/or Scissors		Used to cut heating panel sets from the supply roll.



Use only those crimping tools specifically provided by Calorique.



Nominal spacing when the crimping tool is fully closed is 0.095 inch (2.4 mm).

INSTALL CONTROL DEVICE BOX

Install a junction box for the control device (thermostat). This box should be located, unobstructed, on an inside wall so that the device reads accurately.

PREPARE THE HEATING PANELS

Prepare all heating panels for each room at one time prior to starting installation.

1. Cut the panel(s) to length.
Using a knife or scissors, cut panel sets according to the layout made in Part 1.
2. Attach connectors to one end of each heating panel set.
Center a connector over one end of each bus bar, pressing them in place with finger pressure and then crimp each connector in place using the flat portion of the crimping tool as shown in the following figure.

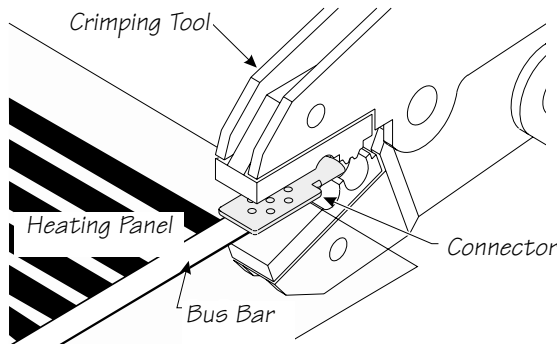

3. Insulate the other end of each bus bar.
Place a length of electrical tape over the exposed end of each bus bar opposite the electrical connector.

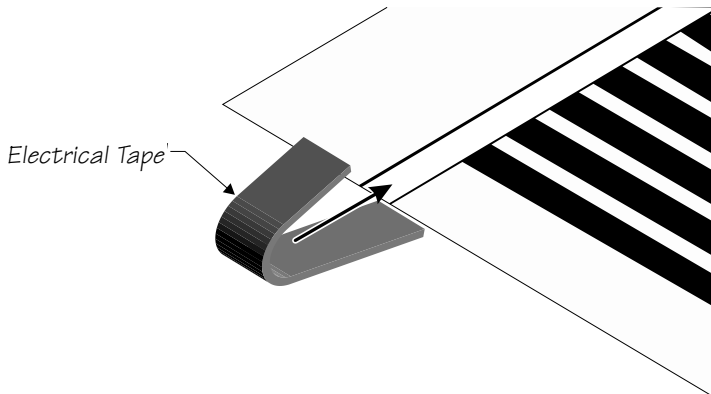

Calorique radiant heating panels must be installed as outlined in these instructions.



Cut heating panels only along the dashed "cut here" lines.



This method may also be used in retrofit applications where the ceiling surface has been completely removed. Remove all screws and nails from the joist surfaces before continuing.

ATTACH HEATING PANELS

Installation in New Construction



Heating panels must run parallel to the joists or nailing strips they are attached to.



Do not pierce the panels within 3/8 inch (10 mm) of the bus bar or heating portion of the panel.



The heating panels must run smooth and flat between the joists. There must be no wrinkles in the heating panels.

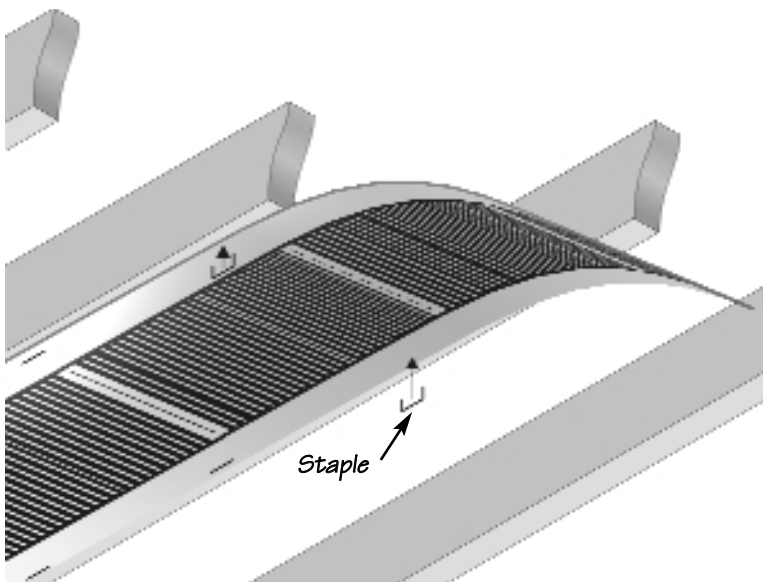

1. Align a heating panel set with the joists or nailing strips to which it will be attached. Make reference to the layout made in Part 1 for heating panel locations.
2. Nail or staple the panel set in place, leaving at least 6 inches (150 mm) clearance to walls or partitions at the connector end for wiring and final assembly. Nails or staples must be placed at least every once every 12 inches (300 mm) along each side of the heating panel set. To make the wiring operations, leave out the last staples at the connection end.
3. Repeat for each heating panel set, then continue to the next section, **Wire the Heating Panel Sets**.

Retrofit Installation

1. Remove all existing insulation from above the existing ceiling.
2. Trim the unheated border of each heating panel set so that it will fit between joists.
3. Lay the heating panels against the ceiling surface. Ensure that there are no wrinkles in the heating panels.
4. Tape the heating panels in place using duct tape. Making sure that the panels remain flat against the ceiling surface are in contact with it for their entire length. Leave approximately 6 inches (150 mm) or so unsecured until you have completed the wiring is completed as detailed in the next section, **Wire the Heating Panel Sets**.

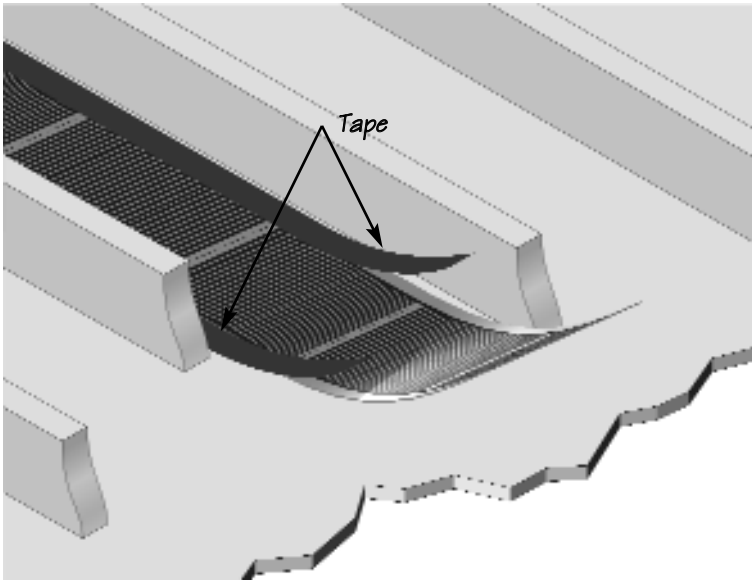

NOTE

Retrofit installations may also be performed by adding furring strips to the room-side of an existing ceiling and then installing the heating panels as described in the new construction installation section. Note that thermal insulation must be installed between the furring strips to eliminate the air gap between them and direct heat down.



This method may be used in those areas where the existing ceiling surface material will not be removed.



The ceiling surface and finish in any area that will receive Calorique radiant heating panels must conform to the restrictions noted on pages 2.



If blown-in or other loose-type insulation is in the joist bay, it may be necessary to vacuum the joist bay to ensure that all insulation has been removed. Insulation which remains will retard heat flow through the ceiling surface and may constitute a fire hazard.



Do not trim the panels closer than 3/8 inch (10 mm) to the bus bar or heating panel portion. Any heating panel which is cut closer than this must be discarded.



See the Calorique Floor Heating System installation manual (CM1004) for complete details on the installation and testing of that system.



Use at least 3 inches (75 mm) of unfaced fiberglass insulation to insulate between the heating panel sets of the two systems. If joists are greater than 6 inches (150 mm) in depth thicker insulation must be used to avoid air pockets above the ceiling heating panel sets.

Ceiling Heating Panels and Floor Heating Panels Installed in the Same Joist Space

NOTE

INTENDED FOR INSTALLATION IN A COMMON JOIST SPACE WITH COMPLEMENTARY FLOOR WARMING PRODUCT RATED 10 WATTS PER SQUARE FOOT MAXIMUM. See the Complementary Heating Products table below for a list of heating elements that may be used in the same joist space.

- If access is from above, completely install the radiant ceiling heating system (including wiring and testing), insulate above the panel sets and then completely install the floor heating system.
- If access is from below, completely install the floor heating system (including wiring and testing), insulate below the heaters and then completely install the ceiling heating system.

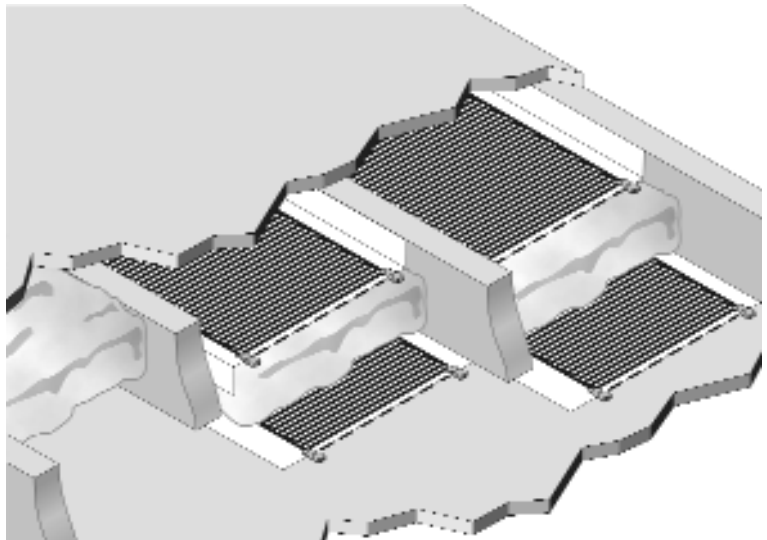

Complementary Heating Products

<i>Ceiling Heating Products</i> ▶		RCH13P13W240V	RCH17P17W240V	RCH25P25W240V
<i>Floor Warming Products</i> ▼		17 W/SF	17 W/SF	17W/SF
FLR13P8W120V	10 W/SF	complementary	complementary	complementary
FLR13P8W240V	10 W/SF	complementary	complementary	complementary
FLR17P10W120V	10 W/SF	complementary	complementary	complementary
FLR17P10W240V	10 W/SF	complementary	complementary	complementary
FLR25P17W120V	10 W/SF	complementary	complementary	complementary
FLR25P17W240V	10 W/SF	complementary	complementary	complementary

WIRE THE HEATING PANEL SETS

Wire the heating panels in parallel according to the following figure. Repeat the steps for each electrical connector.

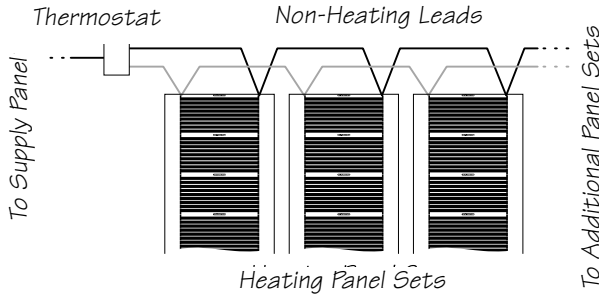

1. Strip the non-heating lead wires (s) that will be attached to the connector. Strip about $\frac{1}{4}$ inch (6 mm).
2. Insert the wire(s) into the barrel section of the connector.
3. Crimp the wires in place using the barrel crimping section of the crimping tool as shown in the following figure.

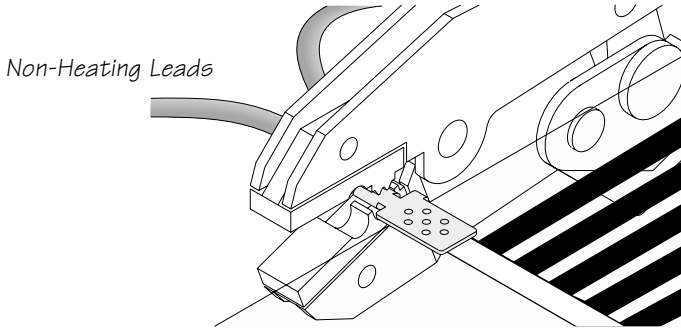

4. Insulate the connector by snapping an insulator in place over it as shown in the following figure.

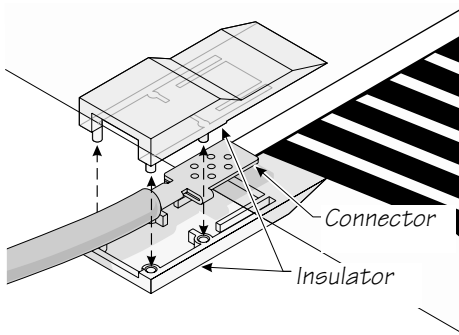

5. Repeat for all of the heating panel sets.
6. If the staples in the final 6 inches of a standard installation were omitted to ease wiring, add these staples now. When performing a retrofit installation, finish taping the heating panel sets to the ceiling surface.



WARNING-
RISK OF
ELECTRIC

SHOCK AND FIRE
DAMAGE TO THE
SUPPLY CONDUCTOR
INSULATION
MAY OCCUR IF
CONDUCTORS ARE
ROUTED LESS
THAN 2 INCHES
(51 MM) FROM
THIS HEATING
PRODUCT. REFER
TO INSTALLATION
INSTRUCTIONS
FOR RECOMMENDED
MEANS OF ROUTING
SUPPLY CONDUCTORS.



One or two wires only
may be crimped into
the barrel section of
the connector.



Route and secure
wires between the
heating panels, from
the heating panels to
the thermostat box
and from the thermostat
box to the electrical
panel using standard
wiring practices that
conform to all of the
requirements of all
applicable electrical
and building codes.

A visual and electrical check must be performed on the heating panels prior to activation.

VISUAL INSPECTION

When visually checking the panels, look for any signs of damage, wear or scratching that might have occurred during installation. If any portions of a panel set appear damaged, replace the entire panel set.

ELECTRICAL TEST

A resistance check across the supply leads using an accurate ohm meter must be made to detect any short or open circuits. If only one type of panel has been used within an area, use the resistance chart in the operating manual to determine the acceptable readings. If more than one type of panel has been used in the area, use the following formulae to determine the acceptable resistance values:

$$\text{high resistance limit} = 63,360 \div \text{total installed watts}$$

$$\text{low resistance limit} = 54,720 \div \text{total installed watts}$$

To determine the total installed watts, multiply the number of individual heating panels by the wattage per panel for each type of panel.

Reading	Indication	Action
Between High & Low	Good	System is connected properly. No action is necessary.
Above High Limit	Open Circuit	Check all electrical connectors and re-crimp or replace any that are attached improperly.
Zero (0)	Short Circuit	Check the path that the wiring is taking and make sure that no wires are attached to both bus bars of a single panel. If any are, remove the wires.

After any remedies have been performed for open or short circuits, if any, retest the system.



If any connectors must be replaced, ensure that the heating panel has not been damaged by removing the original connector. If it has, then the entire panel set must be replaced.



Any connectors which are removed must be replaced. A connector may only be crimped once.

1. Install a ceiling covering in accordance with the designer's notes.
2. Finish the ceiling in any normal fashion.
3. Install thermal insulation.

When using batts, the insulation may be installed in the normal manner.

When using blown-in insulation, install a 2 foot long section of batt insulation over each end of each panel set before blowing in insulation per the following figure.

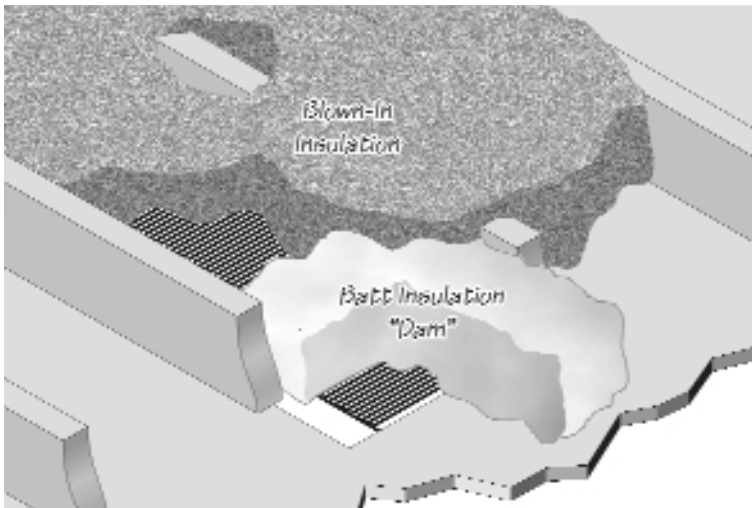

4. Install control device and connect to electrical panel box.
Install and wire the control device according to manufacturer's instructions in the junction box added at the beginning of Part 3 — Installation.



Any material used as a ceiling surface must be appropriate as noted on page 2.



Follow the guidelines on page 2 for ceiling finishes.



See page 3 for more information about thermal insulation.



Batt insulation must be installed before blowing insulation in to ensure that no blown insulation becomes trapped between the heating panel and ceiling covering. Insulation which becomes trapped is a thermal insulator and may cause the panels overheat.



The system labels are an integral part of the heating system and must be attached as noted here. Failure to attach system labels is in violation of the warranty and may result in revocation of the warranty.

5. Attach system labels to the locations noted below:

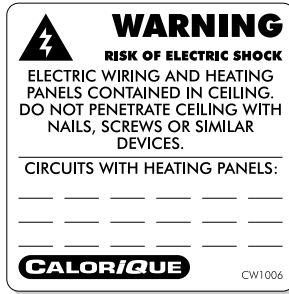

CW1006: Affix to the electrical panel box. In the space provided, record the numbers of all circuits to which ceiling heating panels are attached.



CW1008: Affix to the electrical panel box.



CW1009: Affix adjacent to points of access to all concealed areas in which installed heating products are accessible.



CW1010: Affix to all thermostats controlling radiant heat.

The Check List & System Registration Card records vital information about the installation you have just made — fill out all requested information. The bottom copy is returned to Calorique to register the installation, the other two copies are for the home owner and the installing contractor respectively.

The Operating Manual (contained in a small zipper bag) lists detailed information about the heating system. The manual must be attached to the service panel so that it is easily accessible to the homeowner and any repair and/or remodeling technicians.



The warranty on the system is activated when Calorique returns a warranty card. The warranty card is mailed to the address of the installation only after the system registration card is received by Calorique. Calorique is not responsible for lost or misdirected mail.



2380 Cranberry Highway, West Wareham MA 02576
(508) 291-4224 • (508) 291-2299 fax
www.calorique.com

Copyright © 1997-2007 Calorique, Ltd.
All rights reserved.
Printed in USA